



U.S. Department  
of Transportation

**National Highway  
Traffic Safety  
Administration**

400 Seventh Street, S.W.  
Washington, D.C. 20590

Dear Crash Data Researchers/Users:

Thank you for choosing crash data from the National Highway Traffic Safety Administration (NHTSA) for your research or other use. The information contained in this motor vehicle crash report is collected, maintained and distributed in accordance with Public Law 89-564. In accordance with this Public Law, NHTSA is required not to release any case information until completion of quality control procedures. These procedures include a review of the case material to extract all names, licenses and registration numbers, non-coded interview material, non-research related researcher comments in the margins, non-factual data, and the production number portion of the vehicle identification number (VIN).

If you requested NHTSA to query its database files in order to identify a specific crash, then that query was made using non-personal descriptors you provided for use in our search. This motor vehicle crash may have been identified from a data search and matches the general, non-personal descriptors you provided, but we cannot confirm that this is the specific crash report you requested.

If you have any questions with regard to the above procedures, please contact the Field Operations Branch, Crash Investigation Division, National Center for Statistics and Analysis at 202-366-4820. Again, please be advised that we cannot confirm that this is the case that you have specifically requested nor can we certify the information to be correct.

\*\*\* \*\*



AUTO SAFETY HOTLINE  
(800) 424-9393  
Wash. D.C. Area 366-0123



# PEDESTRIAN CASE SUMMARY

(2)

PSU 82 CASE NO. 608 P TYPE OF ACCIDENT CAR/PEDESTRIAN - CROSSING STRAIGHT

## A. DESCRIPTION OF THE ACCIDENT SEQUENCE AND ACCIDENT PECULIARITIES

(Provide a summary of the accident sequence as well as any particular event of the accident that is noteworthy. Pedestrian injury mechanism and vehicle interaction is the focus, not pedestrian or driver culpability. Do not include any personal identifiers.)

Vehicle #1 was southbound on a 2-way, 2-lane street approaching an intersection and crosswalk.

The pedestrian was walking with another pedestrian to his left.

Prior to impact, this pedestrian saw the vehicle wasn't stopping and accelerated his pace and turned his back and then his left side into the vehicle's path along with pulling the second pedestrian with him.

Vehicle #1 locked up his brakes before and through the impact.

The front right lower valance of the bumper contacted the left foot of the pedestrian.

This pedestrian remained standing after impact.

## B. PEDESTRIAN PROFILE

Pedestrian No.	Age	Sex	Treatment/Mortality	Most Severe Injury (TO BE COMPLETED BY ZONE CENTER)			
				Body Region	Ana. Struc.	AIS	Injury Source
01	28	M	none	No injuries			

Body Region	Type of Anatomic Structure	Abbreviated Injury Scale
Head	Whole Area	(1) Minor injury
Face	Vessels	(2) Moderate injury
Throat	Nerves	(3) Serious injury
Chest	Organs	(4) Severe injury
Abdomen/Pelvis	Skeletal	(5) Critical injury
Spine	Head-LOC	(6) Maximum (untreatable)
Upper Extremity	Skin-Burn	(7) Injured, unknown severity
Lower Extremity	Skin-Other	
External		

## C. VEHICLE PROFILE

Vehicle No.	Class of Vehicle	Year/Make/Model	Most Severe Damage Based on Vehicle Inspection	
			Damage Plane	Damage Description
01	Subcompact	90/Geo/Metro	front	scuffed bumper

**DO NOT SANITIZE THIS FORM**



U.S. Department of Transportation  
National Highway Traffic Safety  
Administration

# ACCIDENT COLLISION DIAGRAM

NATIONAL ACCIDENT SAMPLING SYSTEM  
CRASHWORTHINESS DATA SYSTEM

3

PSU No. 82

Case Number - Stratum 608P

Indicate North

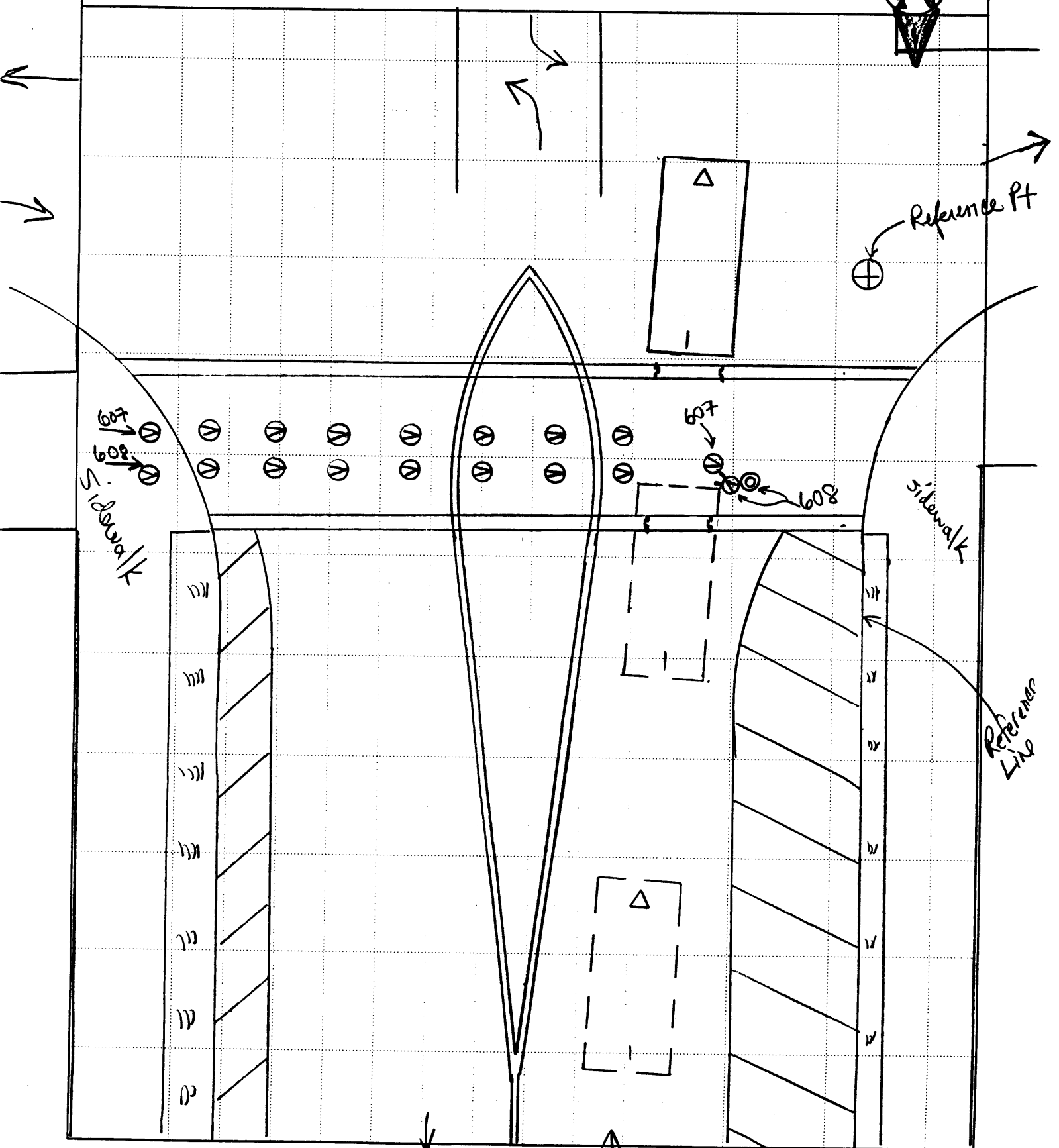



# ACCIDENT COLLISION DIAGRAM

NATIONAL ACCIDENT SAMPLING SYSTEM  
CRASHWORTHINESS DATA SYSTEM

PSU No. 82

Case Number - Stratum 608P

Indicate North



Left side skid

A	5.0W	3.0E
B	5.0W	4.3E
C	2.0W	2.9E
D	5.0W	4.2E

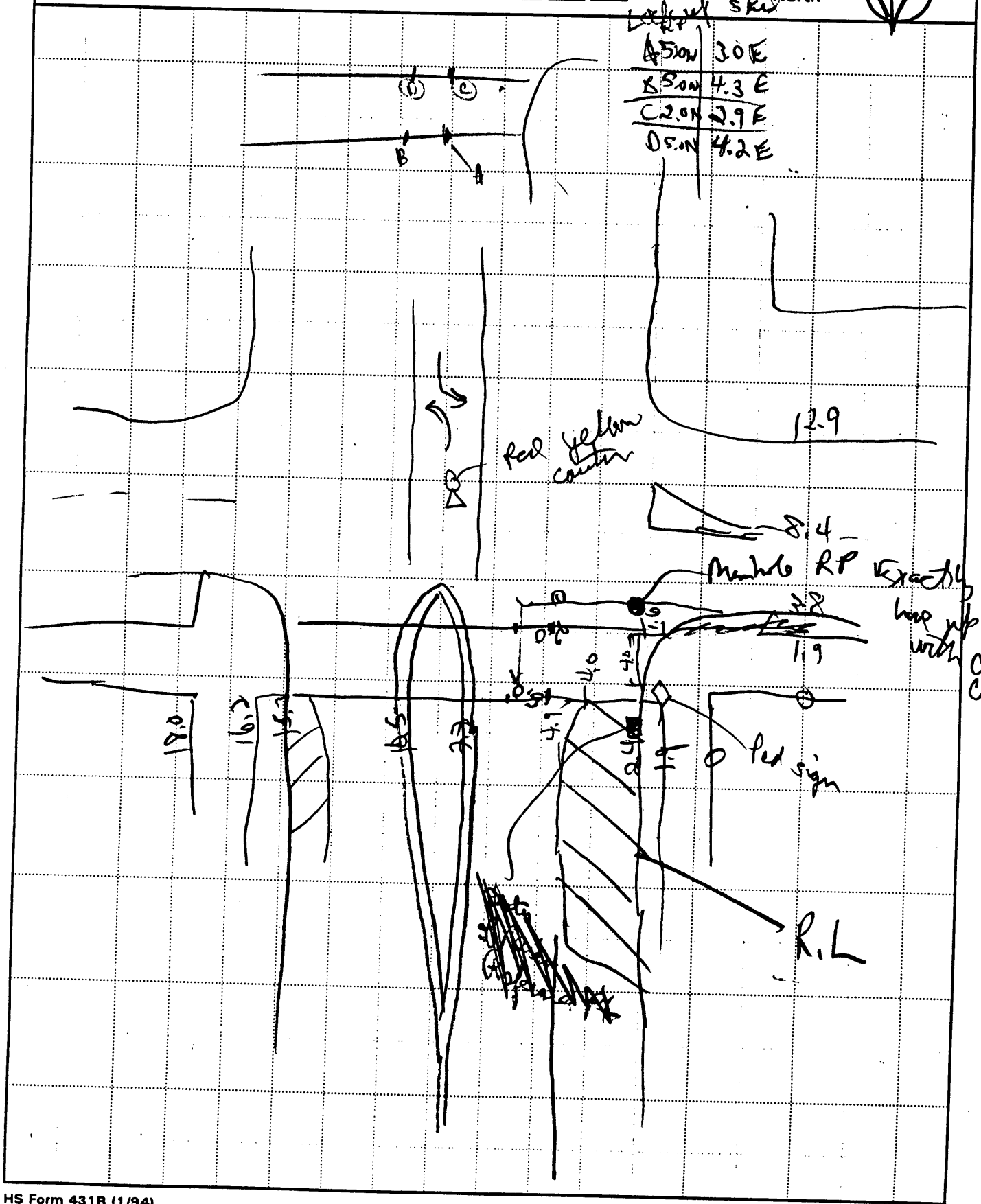



# PEDESTRIAN ACCIDENT COLLISION MEASUREMENT TABLE

Primary Sampling Unit Number 82

Case Number - Stratum 608 P

## PEDESTRIAN ACCIDENT COLLISION DATA COLLECTION

## SCALED DIAGRAM

- \* document reference point and reference line relative to physical features
- \* documentation of all accident induced physical evidence including (if applicable):
  - a) vehicle skid marks
  - b) pedestrian contacts with ground or object
  - c) vehicle/pedestrian point of impact (POI)
  - d) location of pedestrian separation point from vehicle
  - f) final resting points (FRP) for pedestrian and vehicle
- \* documentation of the physical plant including:
  - a) all road/roadway delineation (e.g., crosswalks, curbs/edge lines, lane markings, medians, pavement markings, parked vehicles, poles, signs, etc.)
  - b) all traffic controls (e.g., lights, signs)

Surface Type Bibimus

Surface Condition Wet

Coefficient of Friction .70

Grade (v/h) Measurement

- a) at impact level
- b) between impact and final rest level

Pedestrian Travel Direction West

Vehicle Travel Direction South

Number of Travel Lanes 2

- \* north arrow placed on diagram
- \* grade measurements for all applicable roadways.
- \* scaled representations of the physical plant including:
  - a) all road/roadway delineation (e.g., crosswalks, curbs/edge lines, lane markings, medians, pavement markings, parked vehicles, poles, signs, etc.)
  - b) all traffic controls (e.g., lights, signs)
- \* scaled representations of the vehicle and pedestrian at pre-impact, impact, and final rest based upon either:
  - a) physical evidence, or
  - b) reconstructed accident dynamics

Reference Point: Manhole at N.W. Corner of Intersection

Reference line: West Curb Edge

Item	Distance and Direction from Reference Point	Distance and Direction from Reference Line
The following Lock up Marks were visible on Crosswalk painted lines		
Lock up R.F. Mark	5.0 N	3.0 E
" " "	2.0 N	2.9 E
Lock up L.F. Mark	5.0 N	4.3 E
" " "	2.0 N	4.2 E





# PEDESTRIAN ACCIDENT FORM

1. Primary Sampling Unit Number 82  
2. Case Number - Stratum 6 08 P

## SPECIAL STUDIES - INDICATORS

Check (✓) each special study (SS15-SS19 below) that has been completed; code 1 for the checked special studies and 0 for the special studies not checked.

## IDENTIFICATION

3. Number of General Vehicle Forms Submitted 0 1  
4. Date of Accident (Month, Day, Year) [REDACTED] / 9 4  
5. Time of Accident 1655  
Code reported military time of accident.  
NOTE: Midnight = 2400  
Unknown = 9999

6.  SS15 Administrative Use 0  
7.  SS16 Pedestrian Crash Data Study 1  
8.  SS17 Impact Fires 0  
9.  SS18 \_\_\_\_\_ 0  
10.  SS19 \_\_\_\_\_ 0

## NUMBER OF EVENTS

11. Number of Recorded Events in This Accident 0 1

## PEDESTRIAN STUDY CRITERIA

### Pedestrian Definition:

Any person who is on a trafficway or on a sidewalk or path contiguous with a trafficway, or on private property (e.g., parking lot). Note: Pedestrians include persons who are in contact with the ground, roadway, etc. and are pushing carts, wagons, etc. or holding on to a vehicle.

Persons in or on a nonmotorist conveyance are not pedestrians and are excluded from this study. A nonmotorist conveyance is defined as any human powered device by which a nonmotorist may move, or by which a pedestrian or nonmotorist may move another nonmotorist. A nonmotorist conveyance for purposes of this study includes the following: bicycles, baby carriages, roller skates/blades, push carts, scooters, wheelchairs, animals, etc. For example, persons on a bicycle/scooter, roller skating/blading, in a baby carriage/push cart/wheelchair or on a horse are excluded.

### Case Selection Criteria:

A forward moving, late model year (VEH04 equals 90 to 95) CDS applicable vehicle (VEH07 equals 01 to 49) must strike a pedestrian.

The striking portion of the vehicle structure must be original equipment manufacturer (OEM) without previous damage and or parts removed in the impact area. For example, vehicles equipped with deer guards, winches, snow plows, etc. or previously damaged in the impact area are excluded.

The pedestrian may not be lying or sitting.

The pedestrian impact(s) are the vehicle's only impact(s). If multiple pedestrians are impacted, each pedestrian shall be a separate case.

The first point of contact between the late model year, CDS applicable vehicle and the pedestrian must be forward of the top of the A pillar.

## PEDESTRIAN ACCIDENT EVENTS

Accident Event Sequence Number	Vehicle Number	Class Of Vehicle	General Area of Damage	Vehicle Number or Object Contacted	Class Of Vehicle	General Area of Damage
12. <u>0 1</u>	13. <u>0 1</u>	14. <u>0 1</u>	15. <u>F</u>	16. <u>7 2</u>	17. <u>0 0</u>	18. <u>0</u>

**CODES FOR  
CLASS OF VEHICLE**

- (00) Not a motor vehicle
- (01) Subcompact/mini (wheelbase < 254 cm)
- (02) Compact (wheelbase ≥ 254 but < 265 cm)
- (03) Intermediate (wheelbase ≥ 265 but < 278 cm)
- (04) Full size (wheelbase ≥ 278 but < 291 cm)
- (05) Largest (wheelbase ≥ 291 cm)
- (09) Unknown passenger car size
- (11) Compact utility vehicle
- (12) Large utility vehicle (≤ 4,500 kgs GVWR)
- (13) Passenger van (≤ 4,500 kgs GVWR)
- (14) Other van (≤ 4,500 kgs GVWR)
- (15) Pickup truck (≤ 4,500 kgs GVWR)
- (18) Other truck (≤ 4,500 kgs GVWR)
- (19) Unknown light truck type

**CODES FOR GENERAL AREA  
OF DAMAGE (GAD)**

**CDS APPLICABLE  
VEHICLES**

- (F) Front
- (R) Right side
- (L) Left side
- (U) Undercarriage
- (9) Unknown

**CODES FOR VEHICLE NUMBER OR OBJECT CONTACTED**

**Collision with Nonfixed Object**

- (72) Pedestrian





# PEDESTRIAN ASSESSMENT FORM

5

1. Primary Sampling Unit Number

82

2. Case Number - Stratum

608 P

3. Pedestrian Number

01

10. Pedestrian's Weight  
Code actual weight to the nearest  
kilogram.

070

(999) Unknown

155 pounds X .4536 = \_\_\_\_\_ kilograms

## PEDESTRIAN'S CHARACTERISTICS

4. Pedestrian's Age

28

Code actual age at time of accident.

(00) Less than one year old (specify by month):

(97) 97 years and older

(99) Unknown

5. Pedestrian's Sex

1

(1) Male

(2) Female - not reported pregnant

(3) Female - pregnant-1st trimester (1st-3rd month)

(4) Female - pregnant-2nd trimester (4th-6th month)

(5) Female - pregnant-3rd trimester (7th-9th month)

(6) Female - pregnant-term unknown

(9) Unknown

6. Pedestrian's Overall Height

183

Code actual height to the nearest  
centimeter.

(999) Unknown

72 inches X 2.54 = \_\_\_\_\_ centimeters

52

7. Pedestrian's Height - Ground to Knee

52.15

Code to the nearest  
centimeter.

(999) Unknown

\_\_\_\_\_ inches X 2.54 = \_\_\_\_\_ centimeters

097

8. Pedestrian's Height - Ground to Hip

96.99

Code to the nearest  
centimeter.

(999) Unknown

\_\_\_\_\_ inches X 2.54 = \_\_\_\_\_ centimeters

150

9. Pedestrian's Height - Ground to Shoulder

149.65

Code to the nearest  
centimeter.

(999) Unknown

\_\_\_\_\_ inches X 2.54 = \_\_\_\_\_ centimeters

## PEDESTRIAN'S PRE-AVOIDANCE ACTIONS

11. Pedestrian Attitude

(1) Standing

(2) Crouching

(3) Kneeling

(4) Bending at waist

(8) Other (specify): \_\_\_\_\_

(9) Unknown

1

12. Pedestrian Motion

(0) Not moving

(1) Walking slowly

(2) Walking rapidly

(3) Running or jogging

(4) Hopping

(5) Skipping

(6) Jumping

(7) Falling/stumbling or rising

(8) Other (specify): \_\_\_\_\_

(9) Unknown

1

13. Pedestrian's Action Relative to Vehicle

(00) Stopped

(01) Crossing road, straight

(02) Crossing road, diagonally

(03) Moving in road, with traffic

(04) Moving in road, against traffic

(05) Off road, approaching road

(06) Off road, going away from road

(07) Off road, moving parallel

(08) Off road, crossing driveway

(09) Off road, moving along driveway

(98) Other (specify): \_\_\_\_\_

(99) Unknown

01

14. Pedestrian's Body (Chest) Orientation  
Relative to Striking Vehicle Prior to  
Avoidance Actions

(1) Facing vehicle

(2) Facing away

(3) Left side to vehicle

(4) Right side to vehicle

(8) Other (specify): \_\_\_\_\_

(9) Unknown

4

2. c. Height of center of mass

**PEDESTRIAN'S AVOIDANCE ACTIONS**

15. Pedestrian's First Avoidance Actions 98

- (00) No avoidance actions
- (01) Stopped
- (02) Accelerated pace
- (03) Ran away (along vehicle path)
- (04) Jumped
- (05) Turned toward vehicle
- (06) Turned away from vehicle
- (07) Dove or fell away

Used hand(s) to :

- (11) Vault corner of vehicle
- (12) Vault onto vehicle
- (13) Brace against vehicle
- (14) Crouched and braced hands against vehicle
- (98) Other (specify): accelerated and
- (99) Unknown turn with back to left side exposed to path

**PEDESTRIAN'S ORIENTATION AT IMPACT**

16. Pedestrian's Head Orientation at Initial Impact W

- (1) To front
- (2) To left
- (3) To right
- (4) Up
- (5) Down
- (8) Other (specify): \_\_\_\_\_
- (9) Unknown

17. Pedestrian's Body (Chest) Orientation at Initial Impact 4

- (1) Facing vehicle
- (2) Facing away
- (3) Left side to vehicle
- (4) Right side to vehicle
- (8) Other (specify): \_\_\_\_\_
- (9) Unknown

18. Pedestrian's Arm Orientation at Initial Impact 09

- (01) At sides
- (02) Folded across chest
- (03) Hands clasped behind back
- (04) Hands on hips
- (05) Hands in pockets

One or both arms:

- (06) Extended upward
- (07) Extended to side
- (08) Extended forward bracing
- (09) Extended, holding object (briefcase, suitcase, etc.) Pedestrian 607P
- (10) Holding object (young child, grocery bag, etc.) in arm(s)
- (11) Holding object (young child, grocery bag, etc.) on shoulder(s) or head
- (98) Other (specify): \_\_\_\_\_
- (99) Unknown

19. Pedestrian's Leg Orientation at Initial Impact 06

- (01) Together
- (02) Apart-laterally
- (03) Apart-right leg forward
- (04) Apart-left leg forward
- (05) Apart- forward leg unknown
- (06) Left foot off the ground
- (07) Right foot off the ground
- (08) Both feet off the ground
- (98) Other (specify): \_\_\_\_\_
- (99) Unknown

20. Vehicle/Pedestrian's Interaction 14

- (01) Carried by vehicle, wrapped position
- (02) Carried by vehicle, slid to windshield
- (03) Carried by vehicle, position unknown
- (04) Passed over vehicle top
- (05) Thrown straight forward
- (06) Thrown forward and left of vehicle
- (07) Thrown forward and right of vehicle
- (08) Knocked to pavement, forward
- (09) Knocked to pavement, left of vehicle
- (10) Knocked to pavement, right of vehicle
- (11) Knocked to pavement, run over or dragged by vehicle
- (12) Shunted to left (corner impacts only)
- (13) Shunted to right (corner impacts only)
- (14) Bumped or pushed aside
- (15) Snagged, rotated
- (16) Snagged, dragged by vehicle
- (17) Foot or legs run over
- (98) Other (specify): \_\_\_\_\_
- (99) Unknown

**OFFICIAL RECORDS**

**INJURY CONSEQUENCES**

21. Police Reported Alcohol Presence For Pedestrian

- (0) No alcohol present
- (1) Yes alcohol present
- (7) Not reported
- (9) Unknown

Q

22. Alcohol Test Result For Pedestrian Code actual value (decimal implied before first digit—0.xx)

- (95) Test refused
- (96) None given
- (97) AC (Alcohol Content) test performed, results unknown
- (99) Unknown if test given

96

Source: PAR

23. Police Reported Other Drug Presence For Pedestrian

- (0) No other drug(s) present
- (1) Yes other drug(s) present
- (7) Not reported
- (9) Unknown

Q

24. Other Drug Specimen Test Result For Pedestrian

- (0) No specimen test given
- (1) Drug not found in specimen
- (2) Drug found in specimen, (specify): \_\_\_\_\_
- (3) Specimen test given, results unknown or not obtained
- (9) Unknown

Q

25. Injury Severity (Police Rating)

- (0) O - No injury
- (1) C - Possible injury
- (2) B - Nonincapacitating injury
- (3) A - Incapacitating injury
- (4) K - Killed
- (5) U - Injury, severity unknown
- (6) Died prior to accident
- (9) Unknown

1

26. Treatment - Mortality

- (0) No treatment
- (1) Fatal
- (2) Fatal - ruled disease (specify): \_\_\_\_\_

Q

*Nonfatal*

- (3) Hospitalization
- (4) Transported and released
- (5) Treatment at scene - non-transported
- (6) Treatment later
- (8) Treatment - other (specify): \_\_\_\_\_
- (9) Unknown

27. Type Of Medical Facility (for Initial Treatment)

- (0) Not treated at a medical facility
- (1) Trauma center
- (2) Hospital
- (3) Medical clinic
- (4) Physician's office
- (5) Treatment later at medical facility
- (8) Other (specify): \_\_\_\_\_
- (9) Unknown

Q

28. Hospital Stay

- (00) Not Hospitalized  
Code the number of days (up through 60) that the pedestrian stayed in a hospital.
- (61) 61 days or more
- (99) Unknown

Q Q

29. Working Days Lost

- Code the number of days (up through 60) that the pedestrian lost from work due to the accident
- (00) No working days lost
- (61) 61 days or more
- (62) Fatally injured
- (97) Not working prior to accident
- (99) Unknown

03

due to friend of Red 6030

**STOP - VARIABLES 30 THROUGH 37 ARE COMPLETED BY THE ZONE CENTER**

30. Glasgow Coma Scale (GCS) Score 0 0  
 (at Medical Facility)  
 (00) Not injured  
 (01) Injured - not treated at medical facility  
 (02) No GCS Score at medical facility  
 (03-15) Code the actual value of the initial GCS Score recorded at medical facility.  
 (97) Injured, details unknown  
 (99) Unknown if injured

31. Was the Pedestrian Given Blood? 1  
 (1) No - blood not given  
 (2) Yes - blood given (specify units): \_\_\_\_\_  
 (9) Unknown if blood given

32. Arterial Blood Gases (ABG) - HCO<sub>3</sub> 0 0  
 (00) Not injured  
 (01) Injured, ABGs not measured or reported  
 (02-50) Code the actual value of the HCO<sub>3</sub>  
 (96) ABGs reported, HCO<sub>3</sub> unknown  
 (97) Injured, details unknown  
 (99) Unknown if injured

33. Time to Death 0 0  
 \_\_\_\_\_ Code number of hours from time of accident to time of death up through 24 hours. If time of death is greater than 24 hours, code number of days. (Note: 1 day = 31, 2 days = 32, ... n days = 30 + n up through 30 days = 60)  
 (00) Not fatal  
 (96) Fatal - ruled disease  
 (99) Unknown

34. 1st Medically Reported Cause of Death 0 0

35. 2nd Medically Reported Cause of Death 0 0

36. 3rd Medically Reported Cause of Death 0 0  
 \_\_\_\_\_ Code the Pedestrian Injury from line number(s) for the medically reported injury(s) which reportedly contributed to this pedestrian's death  
 (00) Not fatal or no additional causes  
 (96) Mode of death given but specific injuries are not linked to cause of death. (specify): \_\_\_\_\_

(97) Other result (includes fatal ruled disease) (specify): \_\_\_\_\_  
 (99) Unknown

37. Number of Recorded Injuries for This Pedestrian 0 0  
 \_\_\_\_\_ Code the actual number of injuries recorded for this pedestrian.  
 (00) No recorded injuries  
 (97) Injured, details unknown  
 (99) Unknown if injured

ARE ALL APPLICABLE MEDICAL RECORDS INCLUDED WITH INITIAL SUBMISSION?

NO [ ] YES [✓]

UPDATE CANDIDATE?

NO [✓] YES [ ]

PSU NUMBER  
CASE NUMBER  
YEAR

82  
6087  
1995

# PEDESTRIAN INJURY FORM

*THE FOLLOWING DATA IS NOT INCLUDED IN THIS CASE:*

ENTIRE FORM

PAGE NUMBER (S) \_\_\_\_\_



8

OFFICIAL RECORDS

- 1. Primary Sampling Unit Number 82
- 2. Case Number - Stratum 608 P
- 3. Vehicle Number 01

- 9. Police Reported Travel Speed 999  
Code to the nearest kmph (NOTE: 000 means less than 0.5 kmph)  
(160)159.5 kmph and above  
(999)Unknown  
  
\_\_\_\_ mph X 1.6093 = \_\_\_\_\_ kmph

VEHICLE IDENTIFICATION

- 4. Vehicle Model Year 90  
Code the last two digits of the model year  
(99) Unknown
- 5. Vehicle Make (specify): Geo/ Chevrolet 20  
Applicable codes are found in your NASS PCDS Data Collection, Coding and Editing Manual.  
(99) Unknown
- 6. Vehicle Model (specify): Vectra 034  
Applicable codes are found in your NASS PCDS Data Collection, Coding and Editing Manual.  
(999) Unknown
- 7. Body Type 03  
Note: Applicable codes may be found on the back of this page.
- 8. Vehicle Identification Number  
2C1MS2460L6   
1 2 3 4 5 6 7 8 9 10 11 12 13 14 15 16 17

- 10. Speed Limit 040  
(000) No statutory limit  
Code posted or statutory speed limit in kmph  
(999) Unknown  
25 mph X 1.6093 = \_\_\_\_\_ kmph

- 11. Police Reported Alcohol Presence For Driver 0  
(0) No alcohol present  
(1) Yes alcohol present  
(7) Not reported  
(8) No driver present  
(9) Unknown

- 12. Alcohol Test Result For Driver 96  
Code actual value (decimal implied before first digit—0.xx)  
(95) Test refused  
(96) None given  
(97) AC (Alcohol Content) test performed, results unknown  
(98) No driver present  
(99) Unknown  
  
Source: PAR

- 13. Police Reported Other Drug Presence For Driver 0  
(0) No other drug(s) present  
(1) Yes other drug(s) present  
(7) Not reported  
(8) No driver present  
(9) Unknown

- 14. Other Drug Specimen Test Result For Driver 0  
(0) No specimen test given  
(1) Drug not found in specimen  
(2) Drug found in specimen (specify): \_\_\_\_\_  
(3) Specimen test given, results unknown or not obtained  
(8) No driver present  
(9) Unknown

Left justify; Slash zeros and letter Z (0 and Z)  
No VIN—Code all zeros  
Unknown—Code all nines

# CODES FOR BODY TYPE

## CDS APPLICABLE VEHICLES

### Automobiles

- (01) Convertible (excludes sun-roof, t-bar)
- (02) 2-door sedan, hardtop, coupe
- (03) 3-door/2-door hatchback
- (04) 4-door sedan, hardtop
- (05) 5-door/4-door hatchback
- (06) Station wagon (excluding van and truck based)
- (07) Hatchback, number of doors unknown
- (08) Other automobile type (specify): \_\_\_\_\_
- (09) Unknown automobile type

### Automobile Derivatives

- (10) Auto based pickup (includes El Camino, Caballero, Ranchero, Brat, and Rabbit pickup)
- (11) Auto based panel (cargo station wagon, auto based ambulance/hearse)
- (12) Large limousine - more than four side doors or stretched chassis
- (13) Three-wheel automobile or automobile derivative

### Utility Vehicles ( $\leq 4,500$ kgs GVWR)

- (14) Compact utility (Jeep CJ-2 - CJ-7, Scrambler, Golden Eagle, Renegade, Laredo, Wrangler, Cherokee [84 and after], Dispatcher, Raider, Bronco II, Bronco [78 and before], Explorer, S-10 Blazer, Geo Tracker, Bravada, S-15 Jimmy, Thing, Pathfinder, Trooper, Trooper II, Rodeo, Amigo, Navajo, 4-Runner, Montero, Samurai, Sidekick, Rocky)
- (15) Large utility (includes Jeep Cherokee [83 and before], Ramcharger, Trailduster, Bronco-fullsize [78 and after], fullsize Blazer, fullsize Jimmy, Landcruiser, Rover, Scout)
- (16) Utility station wagon (Chevy Suburban, GMC Suburban, Travelall, Grand Wagoneer, includes suburban limousine)
- (19) Utility, unknown body type

### Van Based Light Trucks ( $\leq 4,500$ kgs GVWR)

- (20) Minivan (Chrysler Town and Country, Caravan, Grand Caravan, Voyager, Grand Voyager, Mini-Ram, Dodge/Plymouth Vista, Aerostar, Villager, Lumina APV, Trans Sport, Silhouette, Astro, Safari, Toyota Van, Toyota Minivan, Previa, Nissan Minivan, Quest, Mitsubishi Minivan, Vanagon/Camper.)
- (21) Large van (B150-B350, Sportsman, Royal, Maxiwagon, Ram, Tradesman, Voyager [83 and before], E150-E350, Econoline, Clubwagon, Chateau, G10-G30, Chevy Van, Beauville, Sport Van, G15-G35, Rally Van, Vandura.)
- (22) Step van or walk-in van ( $\leq 4,500$  kgs GVWR)
- (23) Van based motorhome ( $\leq 4,500$  kgs GVWR)
- (24) Van based school bus ( $\leq 4,500$  kgs GVWR)
- (25) Van based other bus ( $\leq 4,500$  kgs GVWR)
- (28) Other van type (Hi-Cube Van, Kary) (specify): \_\_\_\_\_
- (29) Unknown van type

### Light Conventional Trucks (Pickup style cab, $\leq 4,500$ kgs GVWR)

- (30) Compact pickup (D50, Colt P/U, Ram 50, Dakota, Arrow Pickup [foreign], Ranger, Courier, S-10, T-10, LUV, S-15, T-15, Sonoma, Datsun/Nissan Pickup, P'up, Mazda Pickup, Toyota Pickup, Mitsubishi Pickup)
- (31) Large Pickup (Jeep Pickup, Comanche, Ram Pickup, D100-D350, W100-W350, F100-F350, C10-C35, K10-K35, R10-R35, V10-V35, Silverado, Sierra, R100-R500,)

- (32) Pickup with slide-in camper
- (33) Convertible pickup
- (39) Unknown pickup style light conventional truck type

### Other Light Trucks ( $\leq 4,500$ kgs GVWR)

- (40) Cab chassis based (includes rescue vehicles, light stake, dump, and tow truck)
- (41) Truck based panel
- (42) Light truck based motorhome (chassis mounted)
- (45) Other light conventional truck type
- (48) Unknown light truck type
- (49) Unknown light vehicle type (automobile, utility, van, or light truck)

## OTHER VEHICLES

### Buses (Excludes Van Based)

- (50) School bus (designed to carry students, not cross country or transit)
- (58) Other bus type (e.g., transit, intercity, bus based motorhome) (specify): \_\_\_\_\_
- (59) Unknown bus type

### Medium/Heavy Trucks ( $> 4,500$ kgs GVWR)

- (60) Step van ( $> 4,500$  kgs GVWR)
- (61) Single unit straight truck (4,500 kgs  $<$  GVWR  $\leq$  8,850 kgs)
- (62) Single unit straight truck (8,850 kgs  $<$  GVWR  $\leq$  12,000 kgs)
- (63) Single unit straight truck ( $> 12,000$  kgs GVWR)
- (64) Single unit straight truck, GVWR unknown
- (65) Medium/heavy truck based motorhome
- (67) Truck-tractor with no cargo trailer
- (68) Truck-tractor pulling one trailer
- (69) Truck-tractor pulling two or more trailers
- (70) Truck-tractor (unknown if pulling trailer)
- (78) Unknown medium/heavy truck type
- (79) Unknown truck type (light/medium/heavy)

### Motored Cycles (Does Not Include All-Terrain Vehicles/Cycles)

- (80) Motorcycle
- (81) Moped (motorized bicycle)
- (82) Three-wheel motorcycle or moped
- (88) Other motored cycle (minibike, motorscooter) (specify): \_\_\_\_\_
- (89) Unknown motored cycle type

### Other Vehicles

- (90) ATV (All-Terrain Vehicle) and ATC (All-Terrain Cycle)
- (91) Snowmobile
- (92) Farm equipment other than trucks
- (93) Construction equipment other than trucks
- (97) Other vehicle type
- (99) Unknown body type

**VEHICLE WEIGHT ITEMS**

**RECONSTRUCTION DATA**

15. Vehicle Curb Weight 0740  
 Code weight to nearest 10 kilograms.  
 (045) Less than 450 kilograms  
 (610) 6,100 kilograms or more  
 (999) Unknown  
1620 lbs X .4536 = 735 kgs

18. Impact Speed + 032  
 Nearest kmph  
 (NOTE: 000 means greater than .5 kmph)  
 (160) 159.5 kmph and above  
 (999) Unknown

19. Accuracy Range of Impact Speed Estimate 2  
 (0) No reconstruction  
 (1) Less than 2 kmph  
 (2) ≥ 2 kmph and ≤ 8 kmph  
 (3) ≥ 9 kmph and ≤ 16 kmph  
 (4) ≥ 17 kmph and ≤ 26 kmph  
 (9) Unknown

16. Vehicle Cargo Weight 0000  
 Code weight to nearest 10 kilograms.  
 (000) Less than 5 kilograms  
 (450) 4,500 kilograms or more  
 (999) Unknown  
 \_\_\_\_\_ lbs X .4536 = \_\_\_\_\_ kgs

20. Data Source of Impact Speed 1  
 (0) No impact speed calculated  
 (1) Zone center calculation  
 (2) Police calculation  
 (3) Driver/witness/police estimates

**PRECRASH DATA**

21. Driver's Attention to Driving 1  
 (Prior to Recognition of Critical Event)  
 (1) Full attention to driving  
 (2) Distracted by other occupant  
 (3) Distracted by moving object in vehicle  
 (4) Distracted by outside person, object, or event  
 (5) Talking on cellular phone or CB radio (specify): \_\_\_\_\_  
 (6) Sleeping or dozing while driving  
 (8) Other (specify): \_\_\_\_\_  
 (9) Unknown

22. Pre-Event Vehicle Movement 01  
 (Prior to Recognition of Critical Event)  
 (01) Going straight  
 (02) Slowing or stopping in traffic lane  
 (03) Starting in traffic lane  
 (04) Stopped in traffic lane  
 (05) Passing or overtaking another vehicle  
 (06) Disabled or parked in travel lane  
 (07) Leaving a parking position  
 (08) Entering a parking position  
 (09) Turning right  
 (10) Turning left  
 (11) Making a U-turn  
 (12) Backing up (other than for parking position)  
 (13) Negotiating a curve  
 (14) Changing lanes  
 (15) Merging  
 (16) Successful avoidance maneuver to a previous critical event  
 (97) Other (specify): \_\_\_\_\_  
 (98) No driver present  
 (99) Unknown

**OTHER DATA**

17. Vehicle Special Use (This Trip) 0  
 (0) No special use  
 (1) Taxi  
 (2) Vehicle used as school bus  
 (3) Vehicle used as other bus  
 (4) Military  
 (5) Police  
 (6) Ambulance  
 (7) Fire truck or car  
 (8) Other (specify): \_\_\_\_\_  
 (9) Unknown

**STOP - VARIABLES 18 THROUGH 20 ARE COMPLETED BY THE ZONE CENTER**



## 23. Critical Precrash Event

*This Vehicle Loss of Control Due To:*

- (01) Blow out or flat tire  
 (02) Stalled engine  
 (03) Disabling vehicle failure (e.g., wheel fell off)  
 (specify): \_\_\_\_\_  
 (04) Non-disabling vehicle problem (e.g., hood flew up)  
 (specify): \_\_\_\_\_  
 (05) Poor road conditions (puddle, pot hole, ice, etc.)  
 (specify): \_\_\_\_\_  
 (06) Traveling too fast for conditions  
 (08) Other cause of control loss (specify): \_\_\_\_\_

## (09) Unknown cause of control loss

*This Vehicle Traveling*

- (10) Over the lane line on left side of travel lane  
 (11) Over the lane line on right side of travel lane  
 (12) Off the edge of the road on the left side  
 (13) Off the edge of the road on the right side  
 (14) End departure  
 (15) Turning left at intersection  
 (16) Turning right at intersection  
 (17) Crossing over (passing through) intersection  
 (19) Unknown travel direction

*Other Motor Vehicle In Lane*

- (50) Stopped  
 (51) Traveling in same direction with lower speed  
 (i.e., lower steady speed or decelerating)  
 (52) Traveling in same direction with higher speed  
 (53) Traveling in opposite direction  
 (54) In crossover  
 (55) Backing  
 (59) Unknown travel direction of other motor vehicle  
 in lane

*Other Motor Vehicle Encroaching Into Lane*

- (60) From adjacent lane (same direction)—over left  
 lane line  
 (61) From adjacent lane (same direction)—over right  
 lane line  
 (62) From opposite direction—over left lane line  
 (63) From opposite direction—over right lane line  
 (64) From parking lane  
 (65) From crossing street, turning into same direction  
 (66) From crossing street, across path  
 (67) From crossing street, turning into opposite  
 direction  
 (68) From crossing street, intended path not known  
 (70) From driveway, turning into same direction  
 (71) From driveway, across path  
 (72) From driveway, turning into opposite direction  
 (73) From driveway, intended path not known  
 (74) From entrance to limited access highway  
 (78) Encroachment by other vehicle—details  
 unknown

*Pedestrian or Pedalcyclist, or Other Nonmotorist*

- (80) Pedestrian in roadway  
 (81) Pedestrian approaching roadway  
 (82) Pedestrian—unknown location

- (83) Pedalcyclist or other nonmotorist in roadway  
 (specify): \_\_\_\_\_  
 (84) Pedalcyclist or other nonmotorist approaching  
 roadway (specify): \_\_\_\_\_  
 (85) Pedalcyclist or other nonmotorist—unknown  
 location (specify): \_\_\_\_\_

*Object or Animal*

- (87) Animal in roadway  
 (88) Animal approaching roadway  
 (89) Animal—unknown location  
 (90) Object in roadway  
 (91) Object approaching roadway  
 (92) Object—unknown location  
 (98) Other critical precrash event (specify): \_\_\_\_\_

## (99) Unknown

## 24. Attempted Avoidance Maneuver

- (00) No driver present  
 (01) No avoidance actions  
 (02) Braking (no lockup)  
 (03) Braking (lockup)  
 (04) Braking (lockup unknown)  
 (05) Releasing brakes  
 (06) Steering left  
 (07) Steering right  
 (08) Braking and steering left  
 (09) Braking and steering right  
 (10) Accelerating  
 (11) Accelerating and steering left  
 (12) Accelerating and steering right  
 (98) Other action (specify): \_\_\_\_\_  
 (99) Unknown

## 25. Precrash Stability After Avoidance Maneuver

- (0) No driver present  
 (1) No avoidance maneuver  
 (2) Tracking  
 (3) Skidding longitudinally—rotation less than 30  
 degrees  
 (4) Skidding laterally—clockwise rotation  
 (5) Skidding laterally—counterclockwise rotation  
 (8) Other vehicle loss-of-control (specify): \_\_\_\_\_  
 (9) Precrash stability unknown

26. Precrash Directional Consequences of  
Avoidance Maneuver (Corrective Action)

- (0) No driver present  
 (1) No avoidance maneuver  
 (2) Vehicle stayed in travel lane where avoidance  
 maneuver was initiated  
 (3) Vehicle stayed on roadway but left travel lane  
 where avoidance maneuver was initiated  
 (4) Vehicle stayed on roadway, not known if left  
 travel lane where avoidance maneuver was  
 initiated  
 (5) Vehicle departed roadway  
 (6) Avoidance maneuver initiated off roadway  
 (9) Directional consequences unknown

## ENVIRONMENTAL DATA

27. Relation to Junction W

- (0) Non-junction  
 (1) Interchange area

*Non-Interchange*

- (2) Intersection  
 (3) Intersection-related  
 (4) Drive, alley access related  
 (5) Other non-interchange (specify):

- (6) \_\_\_\_\_  
 (9) Unknown type of non-interchange  
 (9) Unknown if interchange

28. Trafficway Flow 2 V

- (1) Not physically divided (two way traffic)  
 (2) Divided trafficway - median strip without positive barrier  
 (3) Divided trafficway - median strip with positive barrier  
 (4) One way trafficway  
 (9) Unknown

29. Number of Travel Lanes 1 W

- (1) One  
 (2) Two  
 (3) Three  
 (4) Four  
 (5) Five  
 (6) Six  
 (7) Seven or more  
 (9) Unknown

30. Roadway Alignment 1

- (1) Straight  
 (2) Curve right  
 (3) Curve left  
 (9) Unknown

31. Roadway Profile 1

- (1) Level  
 (2) Uphill Grade (> 2%)  
 (3) Downhill Grade (> 2%)  
 (4) Hillcrest  
 (5) Sag  
 (9) Unknown

32. Roadway Surface Type W

- (1) Concrete  
 (2) Bituminous (asphalt)  
 (3) Brick or Block  
 (4) Slag, gravel or stone  
 (5) Dirt  
 (8) Other (specify):

- (9) \_\_\_\_\_  
 (9) Unknown

33. Roadway Surface Condition W

- (1) Dry  
 (2) Wet  
 (3) Snow and slush  
 (4) Ice  
 (5) Sand, dirt or oil  
 (8) Other (specify): \_\_\_\_\_  
 (9) Unknown

34. Traffic Control Device 1

- (0) No traffic control(s)  
 (1) Trafficway traffic control signal (not RR crossing)

*Regulatory or School Zone Sign (Not RR Crossing)*

- (2) Stop sign  
 (3) Yield sign  
 (4) School zone sign  
 (5) Other sign (specify):

- (6) \_\_\_\_\_  
 (7) Warning sign (not RR crossing)  
 (8) Miscellaneous/other controls including RR controls (specify):

- (9) \_\_\_\_\_  
 (9) Unknown

35. Traffic Control Device Functioning W

- (0) No traffic control  
 (1) Not Functioning  
 (2) Functioning  
 (9) Unknown

36. Light Conditions W

- (1) Daylight  
 (2) Dark  
 (3) Dark, but lighted  
 (4) Dawn  
 (5) Dusk  
 (9) Unknown

37. Atmospheric Conditions W

- (1) No adverse atmospheric related driving conditions  
 (2) Rain  
 (3) Sleet  
 (4) Snow  
 (5) Fog  
 (6) Rain and fog  
 (7) Sleet and fog  
 (8) Other (e.g., smog, smoke, blowing sand or dust, etc.) (specify): \_\_\_\_\_  
 (9) Unknown



9

1. Primary Sampling Unit Number	<u>82</u>	3. Vehicle Number	<u>0 1</u>
2. Case Number - Stratum	<u>6 08 P</u>		

**VEHICLE IDENTIFICATION**

VIN 2C1MS2460L6  Model Year 90

Vehicle Make (specify): Geo Vehicle Model (specify): metro

**PEDESTRIAN FRONT CONTACT WORK SHEET**

PEV06 Hood Material	<u>Steel</u>	
PEV08 Hood Length	<u>086</u>	cm ✓
PEV09 Hood Width-Forward Opening	<u>125</u>	cm ✓
PEV10 Hood Width-Midway	<u>127</u>	cm ✓
PEV11 Hood Width-Rear Opening	<u>128</u>	cm ✓
PEV14 Front Bumper Cover Material	<u>Plastic</u>	
PEV15 Front Bumper Reinforcement Material	<u>Steel</u>	

**VERTICAL MEASUREMENTS**

PEV16 Front Bumper-Bottom Height	<u>042</u>	cm ✓
PEV17 Front Bumper-Top Height	<u>054</u>	cm ✓
PEV18 Forward Hood Opening	<u>038</u>	cm ✓
PEV19 Front Bumper Lead	<u>008</u>	cm ✓

**WRAP DISTANCES**

PEV20 Ground to Forward Hood Opening	<u>062</u>	cm ✓
PEV21 Ground to Front/Top Transition Point	<u>075</u>	cm ✓
PEV22 Ground to Rear Hood Opening	<u>157</u>	cm
PEV23 Ground to Base of Windshield	<u>166</u>	cm
PEV24 Ground to Top of Windshield	<u>242</u>	cm
PEV25 Ground to Head Contact	<u>none 000</u>	cm

### VEHICLE DAMAGE SKETCH

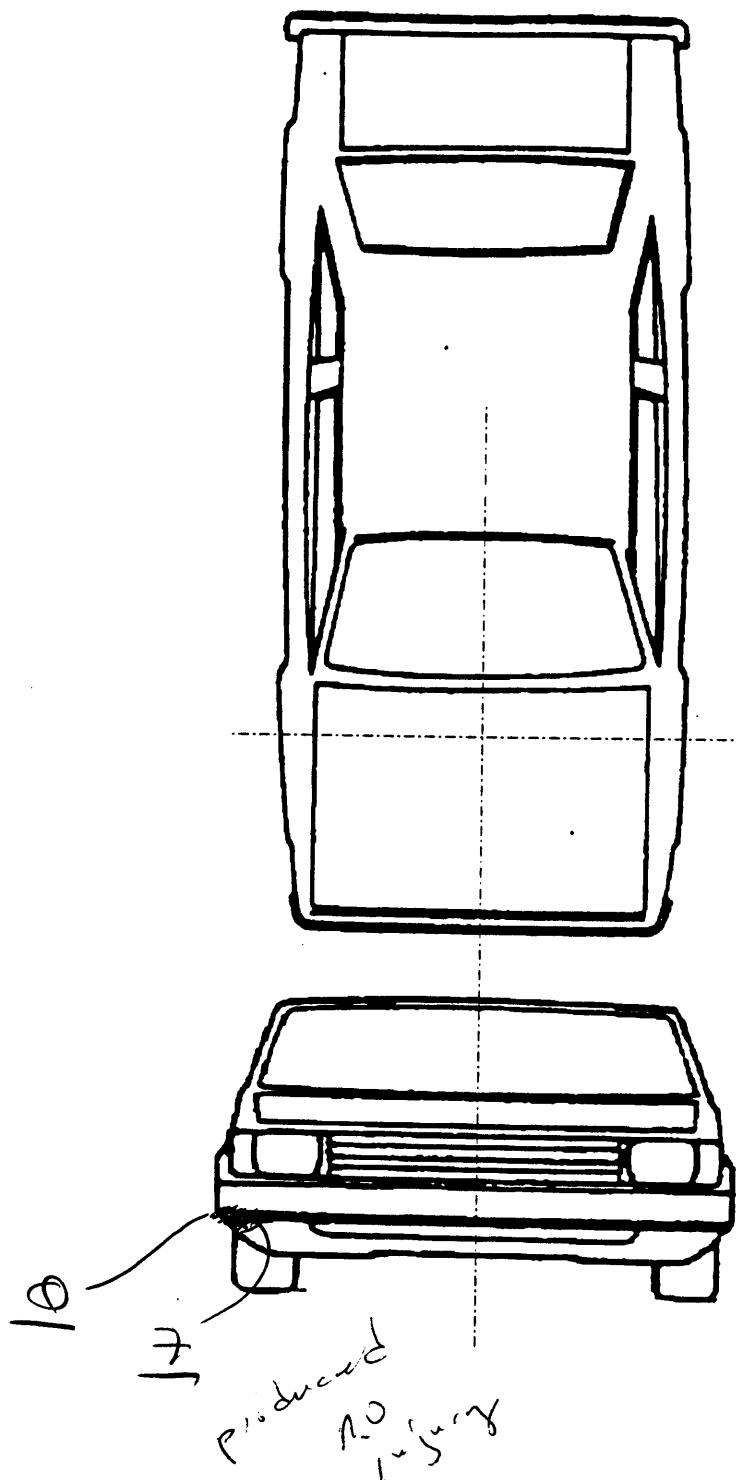

NOTES: Sketch all pedestrian contacts, include the size and depth in centimeters. Locate the pedestrian contacts from the intercept point of the centerline (lateral) and the front axle (longitudinal) in centimeters. Annotate observations which might be useful in reconstructing the accident (e.g., grass in tire bead, direction of striations, scuff on sidewalls, etc.).

Location of the origin (intercept point of the centerline and the front axle) from the ground: 140 cm

Sanitige

9A

VIN 2C1MS2460LB [REDACTED]

Model Year 90

Vehicle Make (specify): Geo

Vehicle Model (specify): Metro

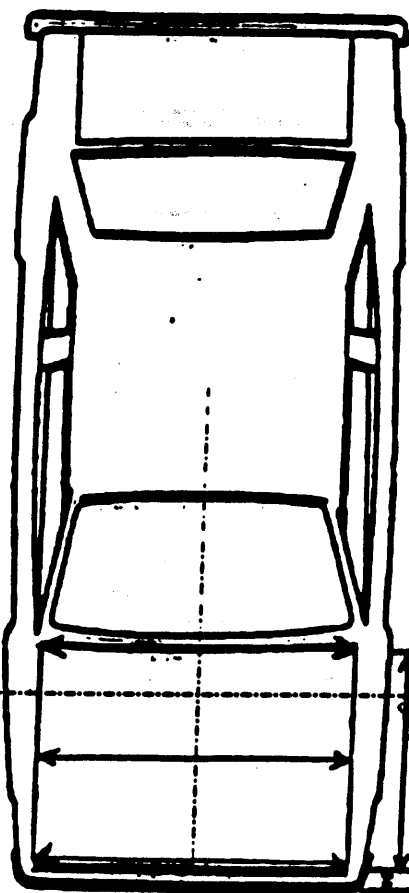

Hood Material

Steel

Front Bumper Cover Material

Plastic

Front Bumper Reinforcement Material

Steel

Hood Widths  
Rear Opening 127

Midway 127

Forward Opening 125

Hood Length

Bumper Lead

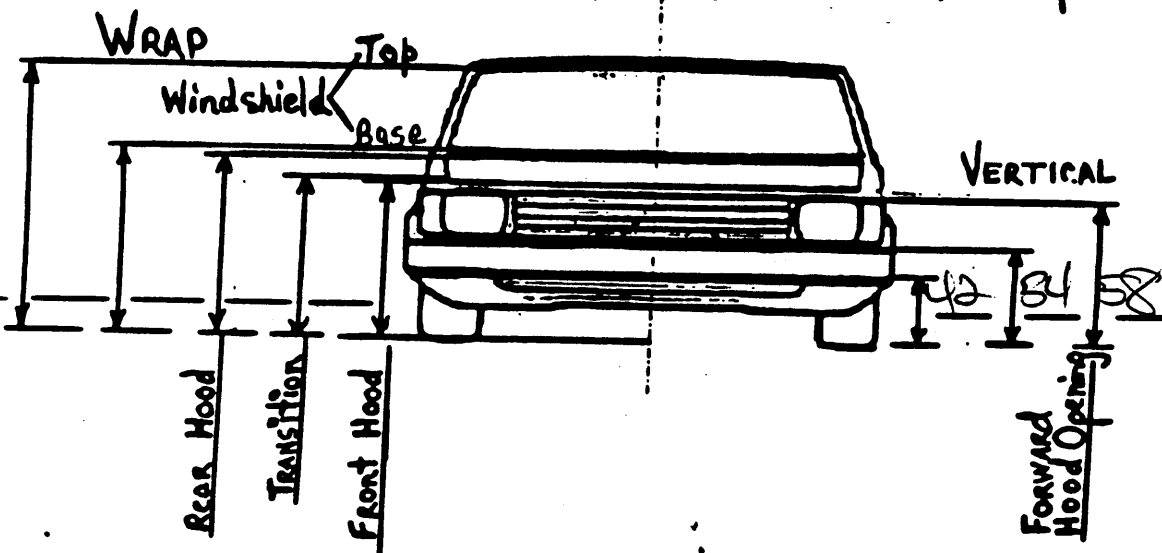

NOTES: Sketch all pedestrian contacts. Include the size and depth in centimeters. Locate the pedestrian contacts from the intercept point of the centerline (lateral) and the front axle (longitudinal) in centimeters. Annotate observations which might be useful in reconstructing the accident (e.g., grass in the track, structure of obstruction, stuff on sidewalk, etc.).

Location of the origin (intercept point of the centerline and the front axle) from the ground: 40 cm

VEHICLE DAMAGE SKETCH

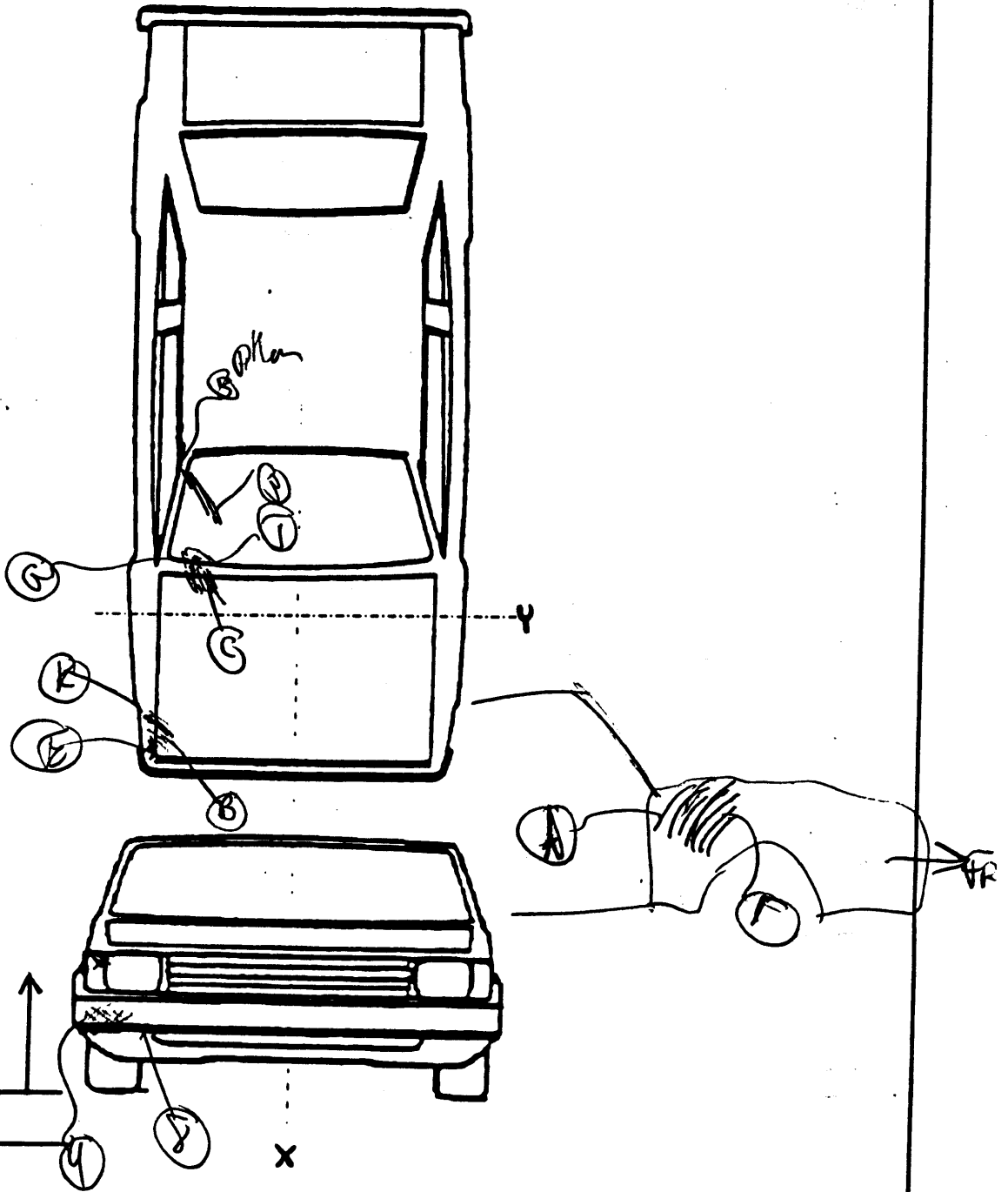

NOTES: Sketch all pedestrian contacts, include the size and depth in centimeters. Locate the pedestrian contacts from the intercept point of the centerline (lateral) and the front axis (longitudinal) in centimeters. Annotate observations which might be useful in reconstructing the accident (e.g., grass in tire bead, direction of skid marks, scuff on sidewalks, etc.).

Location of the origin (intercept point of the centerline and the front axis) from the ground: \_\_\_\_\_ cm

**PEDESTRIAN SIDE CONTACT WORK SHEET**

PEV06 Hood Material \_\_\_\_\_  
 PEV08 Hood Length \_\_\_\_\_ cm  
 PEV09 Hood Width-Forward Opening \_\_\_\_\_ cm  
 PEV10 Hood Width-Midway \_\_\_\_\_ cm  
 PEV11 Hood Width-Rear Opening \_\_\_\_\_ cm

**VERTICAL MEASUREMENTS**

PEV26 Ground Clearance \_\_\_\_\_ cm  
 PEV27 Side Bumper-Bottom Height \_\_\_\_\_ cm  
 PEV28 Side Bumper-Top Height \_\_\_\_\_ cm  
 PEV29 Centerline of Wheel \_\_\_\_\_ cm  
 PEV30 Top of Tire \_\_\_\_\_ cm  
 PEV31 Top of Wheel Well Opening \_\_\_\_\_ cm  
 PEV32 Bottom of A-Pillar at Windshield \_\_\_\_\_ cm  
 PEV33 Top of A-Pillar at Windshield \_\_\_\_\_ cm  
 PEV34 Top of Side View Mirror \_\_\_\_\_ cm

**LATERAL MEASUREMENTS**

PEV35 C<sub>L</sub> to A-Pillar at Bottom of Windshield \_\_\_\_\_ cm  
 PEV36 C<sub>L</sub> to A-Pillar at Top of Windshield \_\_\_\_\_ cm  
 PEV37 C<sub>L</sub> to Maximum Side View Mirror Protrusion \_\_\_\_\_ cm

**WRAP DISTANCES**

PEV38 Ground to Side/Top Transition \_\_\_\_\_ cm  
 PEV39 Ground to Hood Edge \_\_\_\_\_ cm  
 PEV40 Ground to Centerline of Hood (ORIGIN) \_\_\_\_\_ cm  
 PEV41 Ground to Head Contact \_\_\_\_\_ cm

# ORIGINAL SPECIFICATIONS

Wheelbase	— <u>89.2</u>	inches	x	2.54	=		— <u>227</u>	cm
Overall Length	— <u>146.1</u>	inches	x	2.54	=		— <u>371</u>	cm
Maximum Width	— <u>62.</u>	inches	x	2.54	=		— <u>157</u>	cm
Curb Weight	— <u>1620</u>	pounds	x	.4536	=	— <u>735</u>	kg	
Average Track	— <u>52.2</u>	inches	x	2.54	=		— <u>135</u>	cm
Front Overhang	— — — .	inches	x	2.54	=		— — —	cm
Rear Overhang	— — — .	inches	x	2.54	=		— — —	cm
Undeformed End Width	— — — .	inches	x	2.54	=		— — —	cm
Engine Size: cyl./displ.	— — — —	cc	x	.001	=		— <u>1.0</u>	L
	— — — —	CID	x	.0164	=		— .	<u>172</u>



### VEHICLE DAMAGE SKETCH

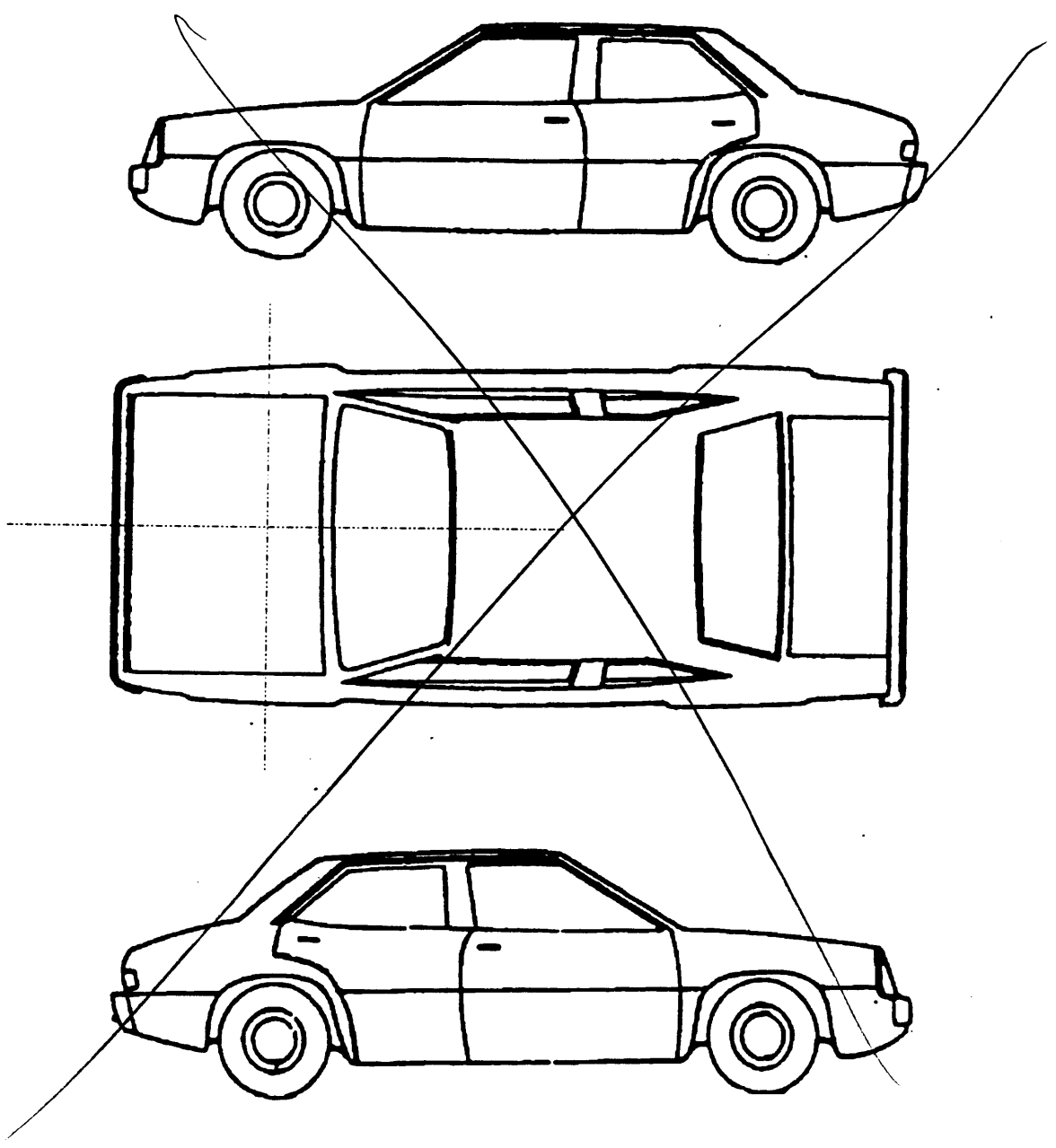

**NOTES:** Sketch all pedestrian contacts, include the size and depth in centimeters. Locate the pedestrian contacts from the intercept point of the centerline (lateral) and the front axes (longitudinal) in centimeters. Annotate observations which might be useful in reconstructing the accident (e.g., grass in tire bead, direction of striations, scuff on sidewalls, etc.).

Location of the origin (intercept point of the centerline and the front axes) from the ground: \_\_\_\_\_ cm

**POINTS OF PEDESTRIAN CONTACT**

**LIST CONTACTS IN CHRONOLOGICAL ORDER**

CONTACT #	COMPONENT CONTACTED CODE	LONGITUDINAL LOCATION (X) (ft)	LATERAL LOCATION (Y) (ft)	CRUSH (Z) (in) CENTIMETERS	SUSPECTED BODY REGION	SUPPORTING PHYSICAL EVIDENCE	CONFIDENCE LEVEL OF CONTACT POINT (Circle)
17	701	67	60	≤ 1	④ Feet	Leather shoes cuff	① 2 3 9
2 ①	701	53	75	≤ 1	④ Feet	and shoe string streaks	① 2 3 9
3		100					1 2 3 9
4							1 2 3 9
5							1 2 3 9
6							1 2 3 9
7							1 2 3 9
8							1 2 3 9
9							1 2 3 9
10							1 2 3 9

**CODES FOR COMPONENTS CONTACTED**

**FRONT**

- 700 Front bumper
- 701 Front Lower valance/spoiler
- 702 Front grille
- 703 Hood edge and/or trim
- 704 Hood ornament (fixed)
- 705 Hood ornament (spring loaded)
- 708 Headlight
- 707 Retractable headlight door (Open/Closed)
- 708 Turn signal/parking lights
- 718 Other front or add on object (specify): \_\_\_\_\_
- 719 Unknown front object

- 743 A2 pillar
- 744 B pillar
- 745 C pillar
- 748 D pillar
- 748 Other pillar (specify): \_\_\_\_\_
- 749 Right side roof rail
- 750 Right side door surface
- 751 Door handle
- 752 Right side mirror fixed housing
- 753 Right side folding mirror
- 754 Right side glazing forward of B pillar
- 755 Right side glazing rearward of B pillar
- 756 Rear antenna
- 757 Rear fender or quarter panel
- 758 Other right side object (specify): \_\_\_\_\_
- 759 Unknown right side component

**Wheels / tires**

- 790 Left front wheel/tire
- 791 Right front wheel/tire
- 792 Left rear wheel/tire
- 793 Right rear wheel/tire
- 798 Other wheel/tire (specify): \_\_\_\_\_
- 799 Unknown wheel/tire

**Undercarriage components**

- 800 Front crossmember
- 801 Steering assembly/Front suspension
- 802 Oil pan
- 803 Exhaust system pipe
- 804 Transmission
- 805 Drive shaft
- 806 Catalytic converter
- 807 Muffler
- 808 Floor pan
- 809 Fuel tank
- 810 Rear suspension
- 818 Other undercarriage component (specify): \_\_\_\_\_
- 819 Unknown undercarriage component

**Left Side Components**

- 720 Front fender side surface
- 721 Front antenna
- 722 A1 pillar
- 723 A2 pillar
- 724 B pillar
- 725 C pillar
- 728 D pillar
- 728 Other pillar (specify): \_\_\_\_\_
- 729 Left side roof rail
- 730 Left side door surface
- 731 Door handle
- 732 Left side mirror fixed housing
- 733 Left side folding mirror
- 734 Left side glazing forward of B pillar
- 735 Left side glazing rearward of B pillar
- 738 Left side back fender or quarter panel
- 737 Rear antenna
- 738 Other left side object (specify): \_\_\_\_\_
- 739 Unknown left side component

**Back Components**

- 780 Rear (back) bumper
- 781 Tailgate
- 782 Hatchback, vertical surface
- 788 Other back component (specify): \_\_\_\_\_
- 789 Unknown back component

**Top Components**

- 770 Hood surface
- 771 Hood surface reinforced by underhood component
- 772 Front fender top surface
- 773 Cowl area
- 774 Wiper blade & mountings
- 775 Windshield glazing
- 778 Front header
- 777 Roof surface
- 778 Backlight glazing
- 779 Rear header
- 780 Hatchback
- 781 Rear trunk lid
- 788 Other top component (specify): \_\_\_\_\_
- 789 Unknown top component

**Accessories**

- 820 Air scoop, deflector
- 821 Cellular or CB radio antenna
- 822 Emergency lights or bar
- 823 Fog lights
- 824 Luggage, ski, or bike rack
- 825 Cargo (specify): \_\_\_\_\_
- 826 Spare tire
- 827 Spotlight
- 828 Other accessory (specify): \_\_\_\_\_

**Right Side Components**

- 740 Front fender side surface
- 741 Front antenna
- 742 A1 pillar

**Other Object or Vehicle in Environment**

- 848 Other object in environment (specify): \_\_\_\_\_
- 849 Unknown object in environment
- 959 Unknown object on contacting vehicle
- 997 Noncontact injury source
- 999 Unknown injury source

POINTS OF PEDESTRIAN CONTACT -- PEDESTRIAN # 1

PEDESTRIAN CONTACT WORKSHEET PAGE

CONTACT ID LABEL	COMPONENT CONTACTED (CODE or OBJECT)	X LONGITUDINAL LOCATION	Y LATERAL LOCATION	CRUSH IN CM	SUSPECTED BODY REGION	SUPPORTING PHYSICAL EVIDENCE	CONFIDENCE LEVEL OF CONTACT POINT
8	Bumper	74	52	Scuff	Legs		3 2 3 9
4	Bumper	65	68				1 2 3 9
A	Lights	+52	64	Cracked		Cracked	1 2 3 9
E	Fender	+47	65	1-2cm			1 2 3 9
B	Hood to	+52	52				1 2 3 9
K	Fender	+19	65				1 2 3 9
C	Hood	-15	50				1 2 3 9
G	Base of	-34	58				1 2 3 9
J	windshield	-32	46				1 2 3 9
A	Fender	0	71		Sweater		1 2 3 9
A	Fender	-36	71		Upper Body		1 2 3 9
3	windshield	-78	43				1 2 3 9
5	windshield	-101	54	Scuff	Arm		1 2 3 9
							1 2 3 9
							1 2 3 9
							1 2 3 9
7	Bumper	67	+66	Scuff	Foot	Scuff Black leather	1 2 3 9
8	Bumper	53	+75			Tracks	1 2 3 9
						for feet	1 2 3 9
						hoff	1 2 3 9
							1 2 3 9
							1 2 3 9
							1 2 3 9
							1 2 3 9
							1 2 3 9

Peel 62

**VEHICLE DIMENSIONS**

4. Original Wheelbase 227  
 \_\_\_\_\_ Code to the  
 nearest centimeter  
 (999) Unknown

89.2 inches X 2.54 = \_\_\_\_\_ centimeters

5. Original Average Track Width 135  
 \_\_\_\_\_ Code to the  
 nearest centimeter  
 (185) 185 centimeters or more  
 (999) Unknown

53.3 inches X 2.54 = \_\_\_\_\_ centimeters

6. Hood Material 3  
 (1) Plastic  
 (2) Fiberglass  
 (3) Steel  
 (4) Aluminum  
 (5) Stainless Steel  
 (8) Other (specify): \_\_\_\_\_  
 (9) Unknown

7. Hood Original 1  
 Equipment Manufacturer (OEM)  
 (1) OEM factory installed hood  
 (2) OEM replacement  
 (3) Non-OEM replacement  
 (9) Unknown

8. Hood Length 086  
 \_\_\_\_\_ Code to the  
 nearest centimeter  
 (180) 180 centimeters or more  
 (999) Unknown  
 \_\_\_\_\_ inches X 2.54 = \_\_\_\_\_ centimeter

9. Hood Width Forward Opening 125  
 \_\_\_\_\_ Code to the  
 nearest centimeter  
 (210) 210 centimeters or more  
 (999) Unknown  
 \_\_\_\_\_ inches X 2.54 = \_\_\_\_\_ centimeters

10. Hood Width Midway 127  
 \_\_\_\_\_ Code to the  
 nearest centimeter  
 (210) 210 centimeters or more  
 (999) Unknown  
 \_\_\_\_\_ inches X 2.54 = \_\_\_\_\_ centimeters

11. Hood Width Rear Opening 128  
 \_\_\_\_\_ Code to the  
 nearest centimeter  
 (210) 210 centimeters or more  
 (999) Unknown

\_\_\_\_\_ inches X 2.54 = \_\_\_\_\_ centimeters

12. Hood/Fender Vertical/Lateral Crush From 2  
 Pedestrian  
 (0) Not damaged  
 (1) Surface scratching only, no residual crush  
 (2) Minor crush (1-3 centimeters)  
 (3) Moderate crush (4-7 centimeters)  
 (4) Severe crush (>7 centimeters)  
 (8) Damage present, unknown if damage is  
 from pedestrian impact  
 (9) Unknown

13. Windshield Contact Damage 0  
 From Pedestrian Contact  
 (0) Not contacted by pedestrian  
 (1) Contacted by pedestrian - not damaged  
 (2) Contacted by pedestrian - damaged  
 (3) Unknown if contacted by pedestrian - not  
 damaged  
 (4) Unknown if contacted by pedestrian -  
 damaged  
 (9) Unknown if contacted by pedestrian -  
 unknown if damaged

**FRONT CONTACT DAMAGE**

**Front Vertical Measurements**

14. Front Bumper Cover Material 1  
 (0) No front contact  
 (1) Plastic  
 (2) Fiberglass  
 (3) Rubber  
 (4) Other (specify): \_\_\_\_\_  
 (9) Unknown

15. Front Bumper Reinforcement Material 1  
 (0) No front contact  
 (1) Steel  
 (2) Aluminum  
 (3) Stainless Steel  
 (4) Other (specify): \_\_\_\_\_  
 (9) Unknown

16. Front Bumper-Bottom Height 042  
 \_\_\_\_\_ Code to the  
 nearest centimeter  
 (000) No front contact  
 (150) 150 centimeters or more  
 (999) Unknown

\_\_\_\_\_ inches X 2.54 = \_\_\_\_\_ centimeters

17. Front Bumper-Top Height 054  
 \_\_\_\_\_ Code to the  
 nearest centimeter  
 (000) No front contact  
 (150) 150 centimeters or more  
 (999) Unknown

\_\_\_\_\_ inches X 2.54 = \_\_\_\_\_ centimeters

18. Forward Hood Opening 058  
 \_\_\_\_\_ Code to the  
 nearest centimeter  
 (000) No front contact  
 (200) 200 centimeters or more  
 (999) Unknown

\_\_\_\_\_ inches X 2.54 = \_\_\_\_\_ centimeters

19. Front Bumper Lead 08  
 (00) No front contact  
 \_\_\_\_\_ Code to the  
 nearest centimeter  
 (30) 30 centimeters or more  
 (99) Unknown

\_\_\_\_\_ inches X 2.54 = \_\_\_\_\_ centimeters

23. Ground to Base of Windshield 166  
 \_\_\_\_\_ Code to the  
 nearest centimeter  
 (000) No front contact  
 (400) 400 centimeters or more  
 (999) Unknown

\_\_\_\_\_ inches X 2.54 = \_\_\_\_\_ centimeters

24. Ground to Top of Windshield 242  
 \_\_\_\_\_ Code to the  
 nearest centimeter  
 (000) No front contact  
 (500) 500 centimeters or more  
 (999) Unknown

\_\_\_\_\_ inches X 2.54 = \_\_\_\_\_ centimeters

25. Ground To Head Contact 000  
 \_\_\_\_\_ Code to the  
 nearest centimeter  
 (000) No front contact  
 (400) 400 centimeters or more  
 (999) Unknown

(578) no head contact  
 \_\_\_\_\_ inches X 2.54 = \_\_\_\_\_ centimeters

**Front Wrap Distance Measurements**

**SIDE CONTACT DAMAGE**

**Side Vertical Measurements**

20. Ground to Forward Hood Opening 062  
 \_\_\_\_\_ Code to the  
 nearest centimeter  
 (000) No front contact  
 (200) 200 centimeters or more  
 (999) Unknown

\_\_\_\_\_ inches X 2.54 = \_\_\_\_\_ centimeters

21. Ground to Front/Top Transition Point 075  
 \_\_\_\_\_ Code to the  
 nearest centimeter  
 (000) No front contact  
 (180) 180 centimeters or more  
 (999) Unknown

\_\_\_\_\_ inches X 2.54 = \_\_\_\_\_ centimeters

22. Ground to Rear Hood Opening 157  
 \_\_\_\_\_ Code to the  
 nearest centimeter  
 (000) No front contact  
 (400) 400 centimeters or more  
 (999) Unknown

\_\_\_\_\_ inches X 2.54 = \_\_\_\_\_ centimeters

26. Ground Clearance 000  
 \_\_\_\_\_ Code to the  
 nearest centimeter  
 (000) No side contact  
 (150) 150 centimeters or more  
 (999) Unknown

\_\_\_\_\_ inches X 2.54 = \_\_\_\_\_ centimeters

27. Side Bumper-Bottom Height 000  
 \_\_\_\_\_ Code to the  
 nearest centimeter  
 (000) No side contact  
 (150) 150 centimeters or more  
 (999) Unknown

\_\_\_\_\_ inches X 2.54 = \_\_\_\_\_ centimeters

28. Side Bumper-Top Height 000  
 \_\_\_\_\_ Code to the  
 nearest centimeter  
 (000) No side contact  
 (150) 150 centimeters or more  
 (999) Unknown

\_\_\_\_\_ inches X 2.54 = \_\_\_\_\_ centimeters

29. Centerline of Wheel

Code to the nearest centimeter  
 (000) No side contact  
 (150) 150 centimeters or more  
 (999) Unknown

\_\_\_\_\_ inches X 2.54 = \_\_\_\_\_ centimeters

000

30. Top of Tire

Code to the nearest centimeter  
 (000) No side contact  
 (200) 200 centimeters or more  
 (999) Unknown

\_\_\_\_\_ inches X 2.54 = \_\_\_\_\_ centimeters

000

31. Top of Wheel Well Opening

Code to the nearest centimeter  
 (000) No side contact  
 (250) 250 centimeters or more  
 (999) Unknown

\_\_\_\_\_ inches X 2.54 = \_\_\_\_\_ centimeters

000

32. Bottom of A-Pillar at Windshield

Code to the nearest centimeter  
 (000) No side contact  
 (250) 250 centimeters or more  
 (999) Unknown

\_\_\_\_\_ inches X 2.54 = \_\_\_\_\_ centimeters

000

33. Top of A-Pillar at Windshield

Code to the nearest centimeter  
 (000) No side contact  
 (300) 300 centimeters or more  
 (999) Unknown

\_\_\_\_\_ inches X 2.54 = \_\_\_\_\_ centimeters

000

34. Top of Side View Mirror

Code to the nearest centimeter  
 (000) No side contact  
 (300) 300 centimeters or more  
 (999) Unknown

\_\_\_\_\_ inches X 2.54 = \_\_\_\_\_ centimeters

000

Side Lateral Measurements

35. Centerline to A-Pillar at Bottom of Windshield

Code to the nearest centimeter  
 (250) 250 centimeters or more  
 (999) Unknown

\_\_\_\_\_ inches X 2.54 = \_\_\_\_\_ centimeters

000

36. Centerline to A-Pillar at Top of Windshield

Code to the nearest centimeter  
 (000) No side contact  
 (250) 250 centimeters or more  
 (999) Unknown

\_\_\_\_\_ inches X 2.54 = \_\_\_\_\_ centimeter

000

37. Centerline to Maximum Side View Mirror Protrusion

Code to the nearest centimeter  
 (000) No side contact  
 (300) 300 centimeters or more  
 (999) Unknown

\_\_\_\_\_ inches X 2.54 = \_\_\_\_\_ centimeter

000

Side Wrap Distance Measurements

38. Ground to Side/Top Transition

Code to the nearest centimeter  
 (000) No side contact  
 (400) 400 centimeters or more  
 (999) Unknown

\_\_\_\_\_ inches X 2.54 = \_\_\_\_\_ centimeters

000

39. Ground to Hood Edge

Code to the nearest centimeter  
 (000) No side contact  
 (500) 500 centimeters or more  
 (999) Unknown

\_\_\_\_\_ inches X 2.54 = \_\_\_\_\_ centimeters

000

40. Ground to Centerline of Hood (Origin) 000

Code to the nearest centimeter

- (000) No side contact
- (700) 700 centimeters or more
- (999) Unknown

\_\_\_\_\_ inches X 2.54 = \_\_\_\_\_ centimeters

41. Ground to Head Contact 000

Code to the nearest centimeter

- (000) No side contact
- (800) 800 centimeters or more
- (999) Unknown

\_\_\_\_\_ inches X 2.54 = \_\_\_\_\_ centimeters

final

82608P00000011 958.0500000000000116550100001 95 95 96 950000000000  
00000000000000 01  
82608P00010012 958.05100000000000101F72000  
82608P00010021 8.05 0000000002811835209715007011014983409061409600100000300  
10000000000000  
82608P01000041 8.05 0000000009020034032C1MS2460L6 99904009600074000003  
22110180033232111221232  
82608P01000051 8.05 0000000002271353108612512712820110420540580806207515716  
6242998000  
82608P9999999900  
000010000000000

PEDESTRIAN ASSESSMENT Occupant: 1  
11  
INTRA ERRORS

OHH1091 2 If TREATMENT PAS26 equals 0, 4 or 5, then  
HH1092 WORKING DAYS LOST PAS29 should equal 00, 01, 97 or 99.

0

PSUB2  
CASE 608P  
CURRENT VERSION: 8.05

ERROR SUMMARY SCREEN  
PEDESTRIAN STUDY

/96

FORM NAME	NUMBER OF DOLLAR SIGNS	NUMBER OF LEVEL 1 ERRORS	NUMBER OF LEVEL 2 ERRORS	VERSION NUMBER CONSISTENT
Pedestrian Accident	0	0	0	Y
Pedestrian Assessment	0	0	1	Y
Pedestrian Injury	0	0	0	Y
Pedestrian General Vehicle	0	0	0	Y
Pedestrian Exterior Vehicle	0	0	0	Y
Total Inter Errors		0	0	
Total Case Errors	0	0	1	